



SRS

SEALED ROTARY SENSORS

INNOVATION IN MOTION

Penny+Giles SRS280 sealed rotary sensors and SRS880 submersible rotary sensors have been specially developed to provide maximum performance under extremes of temperature, humidity, vibration, shock and immersion.

Hybrid track

Penny+Giles proven long life hybrid potentiometer track technology (conductive plastic on wire), provides high stability under extremes of temperature and humidity, with virtually infinite resolution and a track life in excess of 50 million operations. With minimal hysteresis and electrical noise and a self-compensating effect for track wear, this technology allows designers to achieve improved control system accuracy and long-term integrity without increasing system costs.

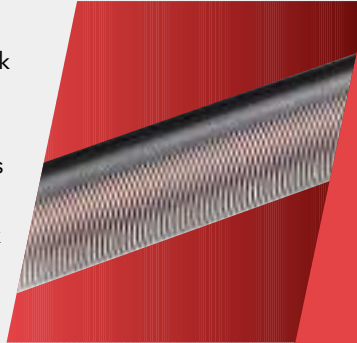

Features

- Electrical angles from 10 to 350°
- Rugged housing and shaft design
 - Sealing up to IP68M
- Crush-proof mounting flange
- Choice of two shaft attachments
 - Duplex shaft bearing support
 - Cable integrally moulded
 - M12 connector
- Rapid despatch of any option
 - CE approved

Benefits

- Maximum sensitivity in all applications
- Suitable for extreme environments
- Operation in hostile environments including submersion
- Allows re-use without damage
- Interchangeable with existing installations
- Optimum performance under vibration
- Secure sealing with excellent strain relief
- Easy installation with mating cabled socket
- Eliminates customer inventory
- Confidence in EMC performance



EMC Directive 2004/108/EC

The products detailed in this document have been tested to the requirements of EN61000-6-3 (Emissions) and EN61000-6-2 (Immunity).



Quality Assurance

Penny+Giles are accredited to BS EN ISO9001:2000. Quality is at the heart of all our systems ensuring the reliability of our products from initial design to final despatch.

Certificate No. LRQ 0924881

ATEX 94/9/EC (100a) and ATEX 1999/92/EC (137) Directives

Penny+Giles SRS280 and SRS880 products are potentiometers and as such are classed as 'simple apparatus' according to the definition in paragraph 3.21 (a) of BS EN 60079-14:1997.

'Simple apparatus' is not certified, but may be used as part of an intrinsically safe circuit providing it is used with a suitable interface of associated apparatus (e.g. a safety barrier).

A full declaration of compliance can be supplied on request.

SRS280 sealed rotary sensor

The SRS 280 sealed rotary sensor has been specially developed to meet the harsh requirements of today's automotive, motorsport and industrial position sensing applications. Interchangeable with the popular 38mm fixing centres format, several innovative features are included to increase reliability and performance over similar devices already in service.

Crush proof inserts

The sensor housing is a high strength glass-filled engineering polymer that has the added feature of stainless steel inserts around the mounting screw area so preventing damage to the flange by over-tightening. This permits the sensor to be re-used after installation and allows minute adjustments to be made.

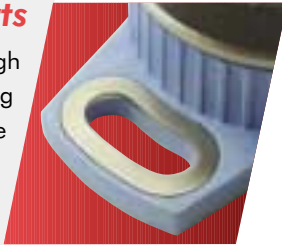

Shaft attachment

The sensor shaft has the option of two attachment formats that are interchangeable with existing installations. The sprung shaft style is a one-piece design that eliminates failures caused by two-piece designs. The shaft can be sealed to meet IP50 or IP68 protection.

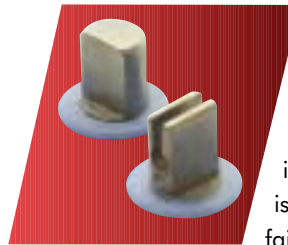

Cable outlet

The sensor rear housing has an integrally moulded cable fully sealed to IP68, effectively eliminating the need to over-fit a moulded boot to improve sealing, thus saving the user time and cost. To facilitate the addition of supplementary heatshrink sleeving over the cable, a small lip on the moulding assists attachment at the sensor housing. Cable lengths of 0.5m and 2m can be specified.



SRS880 submersible rotary sensor

The SRS880 submersible rotary sensor has been specially developed to meet the harsh operating environments in heavy duty industrial position sensing applications, including construction, agricultural and military vehicles, steelworks and power generating plants. The sensor is sealed to meet IP68M protection.

Choice of mounting

The sensor can be mounted by three M6 clearance holes through the body, or alternatively by three M6 threaded attachment holes in the front face. The sensor shaft has a flat on the diameter that would allow it to be secured by a locking screw, or an optional lever kit can be used to attach to the moving surface via a selection of M8 threaded holes.



Rugged design - superior protection

The rugged, 88mm diameter housing in a choice of aluminium or stainless steel, includes a stainless steel operating shaft supported by a heavy duty, twin ball-race bearing system for maximum strength. Environmental protection is achieved by a unique double sealing system that allows the sensor to operate fully submersed to 2m.

SRS 280 SEALED ROTARY SENSOR

PERFORMANCE

ELECTRICAL

Electrical angle ± 2	°	10 to 350 in 10° increments
Resistance $\pm 20\%$	Ω	14.3 per degree
Hysteresis (repeatability)	°	< 0.03
Accuracy		< 1 degree (e.g. $\pm 0.3\%$ over 330°, $\pm 1\%$ over 100°)
Power dissipation at 20°C	W	0.003 W per angular degree
Applied voltage maximum	Vdc	0.2 per angular degree
Resolution		Virtually infinite
Output smoothness		To MIL-R-39023 grade C 0.1%
Insulation resistance		Greater than 100M Ω at 500Vdc
Operating mode		Voltage divider only - see Circuit Recommendation below
Wiper circuit impedance		Minimum of 100 x track resistance or 0.5M Ω (whichever is greater)

MECHANICAL

Mechanical angle	°	360, continuous
Mounting		Use 2 x M4 socket head cap screws and M4 washer - maximum tightening torque 2Nm
Operating torque maximum		
unsealed shaft IP50	gm cm	100
sealed shaft IP68	gm cm	120
Shaft velocity maximum	°/sec	3000
Weight	g	32 (cable option A), 64 (cable option B)
Phasing		When shaft flat (or shaft ident mark) is facing the cable exit, wiper is at mid travel

ENVIRONMENTAL

Life		
unsealed shaft IP50		Exceeds 20 million operations (10 x 10 ⁶ cycles) of $\pm 75^\circ$
sealed shaft IP68		20 million operations (10 x 10 ⁶ cycles) of $\pm 75^\circ$
Dither life		200 million operations (100 x 10 ⁶ cycles) of $\pm 3^\circ$, 60Hz
Operational temperature	°C	-40 to +130 (continuous)
Vibration		RTCA-DO160D, 10Hz to 2000Hz (random), 12.61g rms - all axes
Shock		Survival to 2500g - all axes

CIRCUIT RECOMMENDATION

Hybrid track potentiometers feature a high wiper contact resistance, therefore operational checks should be carried out only in the voltage divider mode. Hybrid track potentiometers should be used only as voltage dividers, with a minimum wiper circuit impedance of 100 x track resistance or 0.5M Ω (whichever is greater). Operation with wiper circuits of lower impedance will degrade the output smoothness and affect the linearity.

OPTIONS

Electrical angle	Can be supplied from 10° to 350° in 10° increments
Shaft style	D or sprung shaft
Shaft sealing	IP50 or IP68
Cable length	0.5m or 2m

AVAILABILITY

All configurations can be supplied within five days from the factory

ORDERING CODES

SRS280/...../...../...../.....

Electrical angle

Shaft style D = D shaft

S = Sprung shaft

Cable A = 0.5m, B = 2m

Shaft sealing 50 = IP50

68 = IP68

DIMENSIONS

Note: drawings not to scale

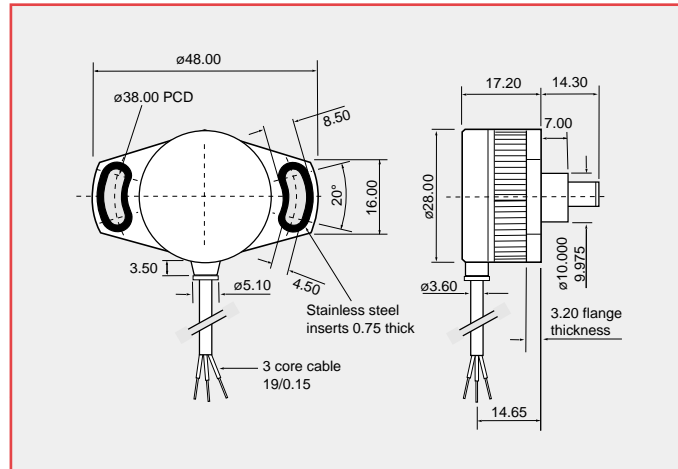

SHAFT OPTIONS

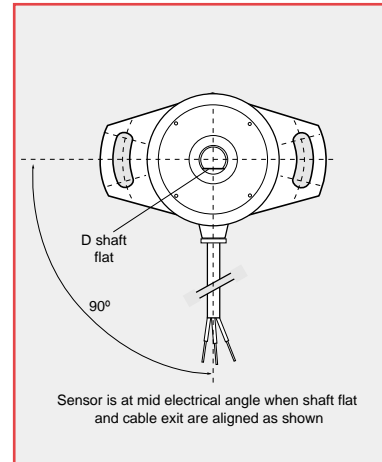
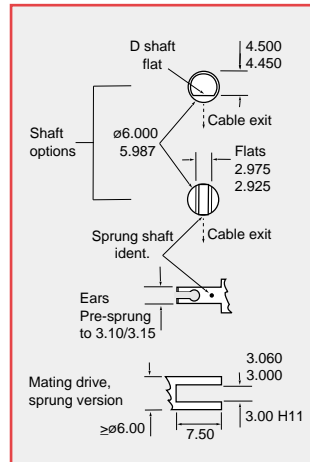

ELECTRICAL CONNECTIONS

3 core cable: PUR sheathed, with PTFE insulated $19/0.15$ cores.

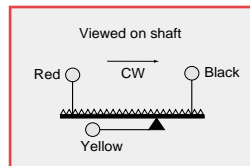

SRS 880 SUBMERSIBLE ROTARY SENSOR

PERFORMANCE

ELECTRICAL

Electrical angle ± 2	°	10 to 350 in 10° increments
Resistance $\pm 20\%$	Ω	14.3 per degree
Hysteresis (repeatability)	°	Less than 0.03
Accuracy		< 1 degree (e.g. $\pm 0.3\%$ over 330°, $\pm 1\%$ over 100°)
Power dissipation at 20°C	W	0.003 per angular degree
Applied voltage maximum	Vdc	0.2 per angular degree
Resolution		Virtually infinite
Output smoothness		To MIL-R-39023 grade C 0.1%
Insulation resistance		Greater than 100M Ω at 500Vdc
Operating mode		Voltage divider only - see Circuit Recommendation below
Wiper circuit impedance		Minimum of 100 x track resistance or 0.5M Ω (whichever is greater)

MECHANICAL

Mechanical angle	°	360, continuous
Mounting		Use 3 x M6 threaded holes in front face or 3 x M6 clearance holes through the body. See dimensions for details
Operating torque max	gm cm	1000
Shaft velocity max	°/sec	3000
Weight	g	500
Phasing		When through hole in shaft (and shaft flat) are 90° from scribed mark on front face, wiper is at mid travel, $\pm 3^\circ$

ENVIRONMENTAL

Sealing		IP68M
Shaft seal life		> 20 million operations (10 x 10 ⁶ cycles) of $\pm 75^\circ$
Operational temperature	°C	-40 to +130 (continuous - sensor only)
Vibration		RTCA-DO160D, 10Hz to 2000Hz (random), 12.61g rms - all axes
Shock		Survival to 2500g - all axes
Explosive atmospheres		Classed as 'simple apparatus' under BS EN 60079-14:1997

CIRCUIT RECOMMENDATION

Hybrid track potentiometers feature a high wiper contact resistance, therefore operational checks should be carried out only in the voltage divider mode. Hybrid track potentiometers should be used only as voltage dividers, with a minimum wiper circuit impedance of 100 x track resistance or 0.5M Ω (whichever is greater). Operation with wiper circuits of lower impedance will degrade the output smoothness and affect the linearity.

OPTIONS

Electrical angle		Can be supplied from 10° to 350° in 10° increments
Cabled socket		2m or 5m cabled socket assemblies available (rated -25 to +90°C only)
Operating levers		Operating levers 155 or 230mm. See details on page 7
Body material		Available with anodised aluminium or corrosion resistant stainless steel housing
Flameproof enclosure		Please contact our sales team for details on our capabilities.

AVAILABILITY

All configurations can be supplied within ten days from the factory

ORDERING CODES

SRS880/...../...../.....

Electrical angle

Body material
 AL = Aluminium
 SS = Stainless steel

Cabled socket
 00 = None
 02 = 2m
 05 = 5m

DIMENSIONS

Note: drawings not to scale

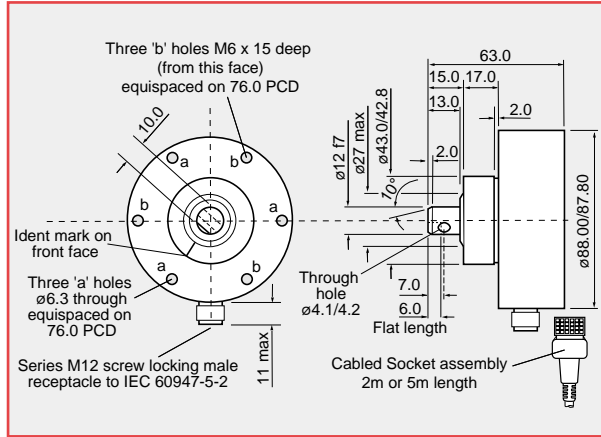

LEVER OPTIONS

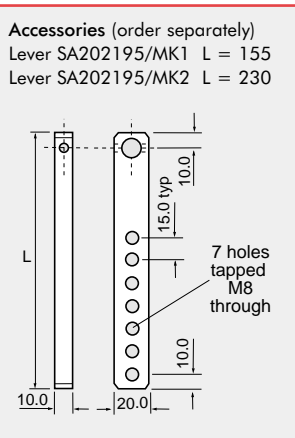

ELECTRICAL CONNECTIONS

Straight cabled socket

E Series M12 to IEC 60947-5-2,
 PUR jacket
 Conforms to VDE 0472 part 804
 -25° to +90°C temperature range[†]

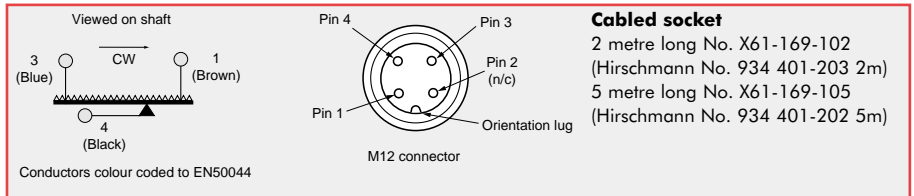

[†]Higher temperature rated versions are available.
 Please consult with our sales team or contact Hirschmann.

Penny+Giles

A Curtiss-Wright Company

www.pennyandgiles.com

Penny & Giles

Position sensors and joysticks for commercial and industrial applications.

15 Airfield Road
Christchurch
Dorset BH23 3TG
United Kingdom
+44 (0) 1202 409409
+44 (0) 1202 409475 Fax
sales@pennyandgiles.com

36 Nine Mile Point Industrial Estate
Cwmfelinfach
Gwent NP11 7HZ
United Kingdom
+44 (0) 1495 202000
+44 (0) 1495 202006 Fax
sales@pennyandgiles.com

5875 Obispo Avenue
Long Beach CA 90805
USA
+1 562 531 6500
+1 562 531 4020 Fax
us.sales@pennyandgiles.com

Straussenlettenstr. 7b
85053 Ingolstadt,
Germany
+49 (0) 841 61000
+49 (0) 841 61300 Fax
info@penny-giles.de

The information contained in this brochure on product applications should be used by customers for guidance only. Penny+Giles Controls Ltd makes no warranty or representation in respect of product fitness or suitability for any particular design application, environment, or otherwise, except as may subsequently be agreed in a contract for the sale and purchase of products. Customer's should therefore satisfy themselves of the actual performance requirements and subsequently the products suitability for any particular design application and the environment in which the product is to be used.

Continual research and development may require change to products and specification without prior notification. All trademarks acknowledged.

© Penny+Giles Controls Ltd 2008

Innovation In Motion

**CURTISS
WRIGHT** Controls
Integrated Sensing

www.cwcontrols.com